

CASE
STUDY



How to optimize the selection of parts with different shapes: Dimac mcv3 Sorting Machine with Double Feeding Cabin

The Dimac mcv3 is a metal table sorting machine designed to inspect oversized **metal parts from M6 up to 1 kg, optimized for bolts and hangable metal components.**

Thanks to its modular structure Dimac mcv3 solves the problem of selecting parts with various shapes and sizes.

In this case study, most of the parts to be selected consist of **bolts and ball-pins** but the customer's request is using a single machine also for **bushings**.

The result was a machine with a double feeding cabin.



BALL PINS



BOLTS



BUSHING

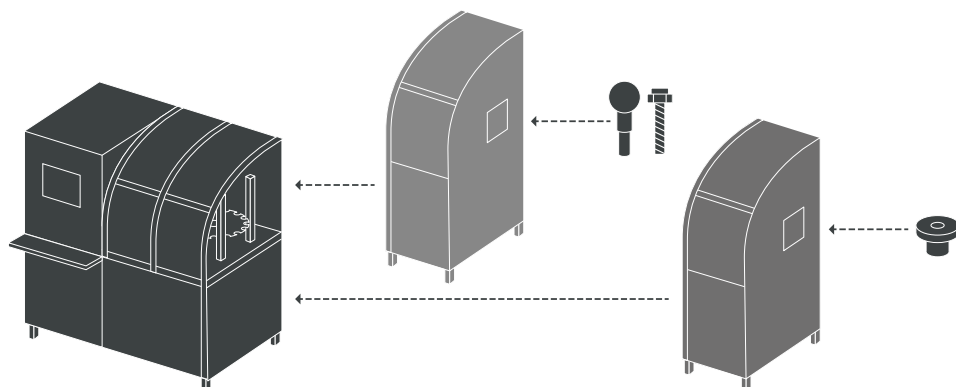

DIMAC MCV3 WITH DOUBLE FEEDING CABIN

CASE STUDY

Modular Feeding Cabin Design

The 100% selection of two types of pieces with very different shapes poses the greatest problems in the loading phase: in fact, it is not possible to use the same vibro-feeder for both. For this reason, Dimac has created a machine with **two different, complete, independent, and interchangeable feeding cabins**, making it possible to **change them**, guaranteeing two configurations perfectly calibrated on the parts to be selected.

After replacing the vibro-feeder it will be sufficient to replace the metal table, adjust the control stations and proceed with the control recipe change, as usual. The complete operation is carried out independently by the customer.

- » **Interchangeable Feeding Cabins** for Format changeover
- » **Efficient Loading Mechanism:** vibro-feeders for different part shapes
- » **Calibration:** after the feeding cabin change, setup of the metal table, control stations, and control recipe loading
- » **User-Friendly Operation**



BALL-PINS FEEDER



BUSHING FEEDER

Why choose a metal disc to manage the bushings

Sometimes choosing the best machine to select an item is counterintuitive. Choosing a glass table machine to select the bushings would seem obvious, but for some types of controls a metal disc machine like the mcv3 can give more satisfaction.

In this case study, for example, **it was necessary to detect the cracks on the maximum diameter of the piece with an eddy current control station**, which cannot be mounted on a glass table machine.

Only a company with complete know-how like Dimac, with more than 35 years of experience in fastener control and selection, is able to satisfy a request like this.

The solution is therefore **a metal table sorting machine with indexed movement to place the crack control station alongside a 360° rotation column.**

Innovation technology: The new bottom recess control station

The amortized bottom recess control station is used for the first time on Dimac mcv3. With a mechanical bit, it allows verification of the presence and depth of a Torx impression on the bottom of a ball-pin.



Robust Mechanical Design to select components up to 1 kg

The machines for large metal components selection are characterized by:

- **mechanical solutions, to respond to the physical stresses**
- **large optics** to frame the entire dimension of the piece
- management of pieces with **large tolerances** and which require increased space and control systems capable of responding adequately both for pieces at the lower limit and at the upper limit of tolerance (for example crack probes).

- » **Durable Components and Optimized Motion Systems** for heavy metal parts moving
- » **Electronic Optimization** for dust and vibration resistance
- » **Sound-absorbing Insulation** to minimize noise

CASE STUDY



In this case study for example we see some large pieces: **ball-pins and bolts weighing well over 100 grams.**

To respond to these needs Dimac has designed the mcv3 model.

A dedicated feeding system, particular attention to the movement of the pieces both when the machine is loaded and unloaded. Vibrating linear guides make it easier for the pieces to enter the table; larger vibrators allow reliability over time; upgraded motion motor and sturdy steel discharge chutes.

The electronic part is also optimized to respond to vibrations and dust. For this reason, the mcv3 machines are equipped with fanless PCs, IP55 electrical panels conditioned with a closed circuit system to make them free from dust, sound-absorbing insulation cabins, especially on the vibrator.



Conclusion

By focusing on modularity, efficiency, user-friendliness, and robustness, the Dimac mcv3 Sorting Machine can be optimized for the selection of various production shapes. It can check the parts described (Ball Pin and bushing), but **thanks to its versatility the same machine is also able to perform checks on parts of smaller dimensions, for example M6x40.** This will not only enhance operational flexibility but also ensure high-quality inspection and sorting of different metal components.

Dimac mcv3 sorting machine: flexible, strong, powerful solution for large dimension parts 100% inspection.